

# FlowLoad

## Long Reach Hose Loading Arm



The BLA-100 is a fixed length boom type arm with a base swivel for horizontal movement and an optional vertical swivel and spring balance for vertical movement. It is typically used for railway and heavy plant refuelling where an extended reach is required from the fixed filling system. It can be used for fuels and chemicals.

The arms are designed to reduce manual handling issues when working with heavy hoses and couplers and provide a way to easily reach fuelling points when the location can change

### Features and Benefits

- Horizontal swivel joint makes it easy to move into correct fuelling position.
- Carbon steel boom arm with durable powder coated finish for long life
- High mounting location allows for clear working space around fuelling station
- Available with range of options including break-away couplings, hoses, filling couplers and control valves.

### Uses Include

- Train refuelling – Our arms are regularly used on high speed train refuelling dispensers
- Heavy plant refuelling including mining and marine bunkering systems
- IBC loading – Can be used for splash or bottom filling of IBC containers
- Ideal for many other liquid fuels and chemicals

### Safety by Design

## Specifications

Technical Features			
Nominal diameter		2" / 3"	
Fluid Type		Hydrocarbons	
Nominal Flow Rate	m <sup>3</sup> /h	30	
	l/min	500	
Max Flow Rate	m <sup>3</sup> /h	38	
	l/min	650	
Design Temperature		-15°C / +65°C	
Weight (kg)		150	
Design Pressure		7 bar	
Test Pressure		10 bar	

### Standard Model Shown

- 1 Stand-post
- 2 Base swivel
- 3 Carbon steel swing boom arm
- 4 Breakaway coupling
- 5 Drop hose
- 6 Filling coupler / nozzle

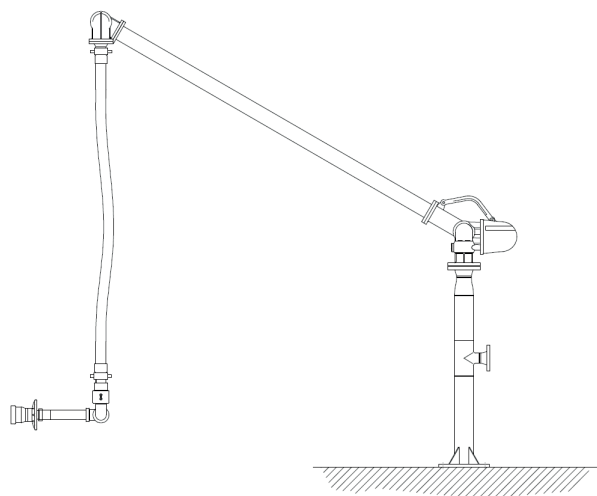

## Options & Accessories

- Arm materials – Boom arm made of aluminium or stainless steel
- Stand post available to specific height
- Double base swivel for vertical movement
- Torsion spring balance for easy handling
- Flanged or threaded end connections
- Break-away couplings
- Fuel or chemical resistant hoses
- Dry disconnect, rail flyte or trigger nozzle end connections

**ifcinflow**

Unit 3 Ryder Way  
Basildon  
Essex SS13 1QH

**Safety by Design**

ifcinflow.com  
+44 (0) 1268 596 900  
sales@ifcinflow.com

