

# LowTank ISO tanker safety cage

**MOBILE FALL PREVENTION SOLUTIONS**

**PREVENT FALLS FROM HEIGHT WHILST WORKING ON THE BACK OF ISO TANK CONTAINERS**

## Features and Benefits

- Fixed three rail safety cage helps prevent operators from falling from back or sides of trailers
- Long cage sides ensure whole of working area is covered
- Safety clip and cords to secure cage sides to tank container
- Extra wide stairs make carrying hoses or specialist PPE easy and trip free
- One person operation allows easy positioning and access
- Large castor wheels ensure good operation on uneven ground
- Provides safe working area and increases operator confidence



## Uses include:

- Tank container loading and unloading
- Accessing tank container ladders
- Working on the back of the truck skeletal trailers and flat bed trailers

**Meets all Health and Safety requirements for operator safety whilst working at height**

S1075A Datasheet

**SAFE TANKER ACCESS SOLUTIONS**

# Leaders in tanker access

## Technical data:

### Materials :

Frame & Cage: Mild carbon steel  
Finish: Corrosion resistant powder coated  
Castors: 200mm Solid rubber with sealed bearings  
Carabiners: Stainless steel with plastic coated steel cords

### Dimensions:

Top step height = 1.166m  
Safety cage area = 2.06m long x 2.47m wide  
Safety cage height = 1.05m  
Access step width = 800mm  
Ground clearance = 95mm

### Stability:

Cage designed to free stand or can be connected to side of tank containers for additional support  
Wheel diameter: 200mm

### Operation:

Safe single operator use and access  
Max safe working weight limit = 150kg  
Rear castors fitted with foot operated brakes  
Spring loaded safety gate at top of steps

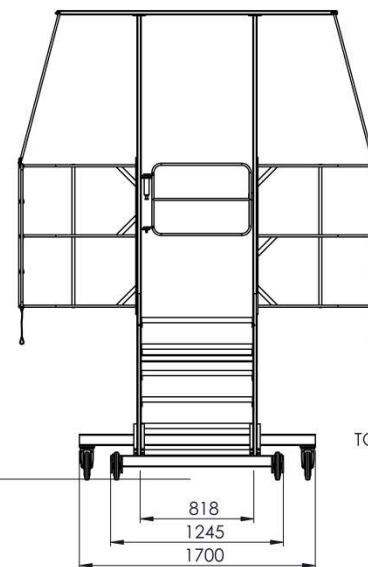
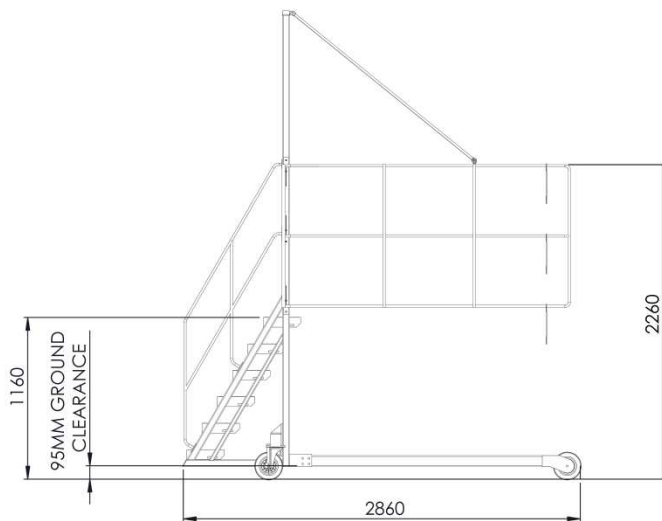
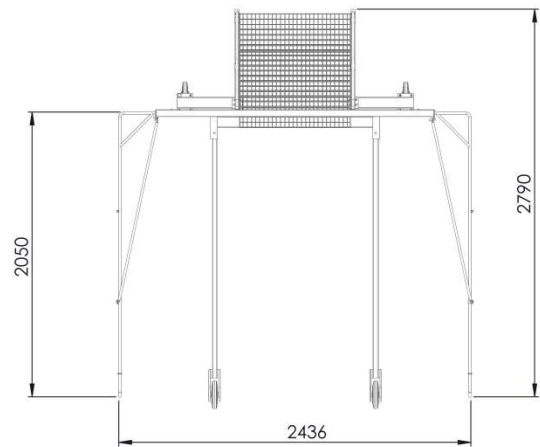

6 OFF  
CAGE SAFETY CABLE  
INCLUDING CARABINA  
TO FIX CAGE TO THE TRUCK

For all **YOUR** tanker fall prevention solutions



INDUSTRIAL FLOW CONTROL LTD, 3 RYDER WAY, BASILDON, ESSEX. SS13 1QH. UK

T: +44 1268 596900 E: sales@IFCinflow.com